

CAD FILE :

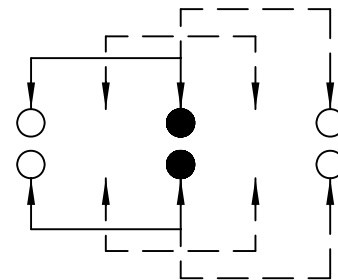

SCHEMATIC (NON-SHORTING)

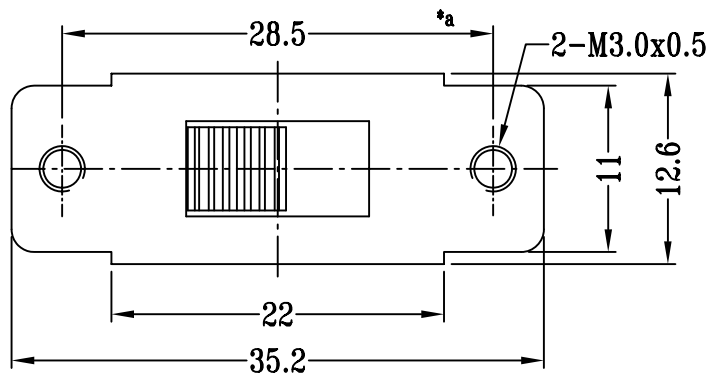
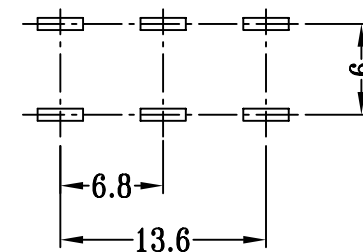
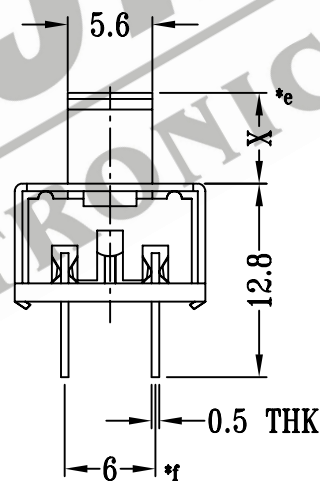
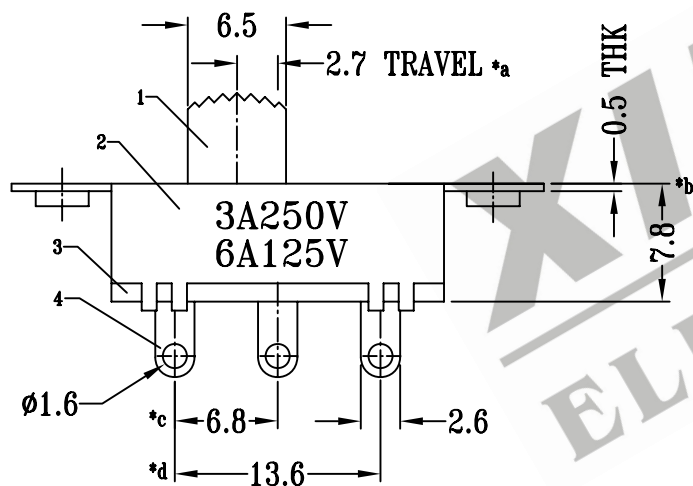

P.C.B LAYOUT

注:带"*"表示关键尺寸(6个)

8	CONTACT CLIP	PBS STRIP	2	Ag PLATED	TOLERANCE UNLESS SPECIFIED	SHENZHEN XIEJIA ELECTRONICS CO.,LTD.				
7	POSITION PLATE	STEEL STRIP	1	Ni PLATED						
6	STEEL BALL	STEEL	1	NATURAL	WITHIN: 1.5±0.1mm OVER : 1.5±0.2mm	ISSUE	DATE	DESCRIPTIONS		APPD
5	SPRING	STEEL WIRE	1	TEMPER						
4	TERMINAL	BRASS STRIP	6	Ag PLATED OVER Ni PLATED	TITLE: VERTICAL SLIDE SWITCH		UNIT : M M	DRWG NO : XJ-DR-SS23E15-00		
3	TERMINAL BASE	PHENOLIC RESIN	1	BLACK	MODEL: SS-23E15		SCALE : 2:1	DWN.	ZHOUYU	2004-9-8
2	FRAME	STEEL STRIP	1	Ni PLATED				CHK'D	FANGYING	2004-9-8
1	KNOB	PC	1	BLACK	ALL MATERIALS MUST BE COMPLIANT TO ROHS		APPD.	KANGXINAN	2004-9-8	
NO.	PART NAME	MATERIAL	QTY.	FINISHING						